



# PNEUMATIC FENDER ACCESSORIES

## Inspection Report

Product Name: Pneumatic fender  $\Phi$  1500x3000L

Purchase order: PNE-STOCK ORDER 001-P.O. NO.90670

Initial Internal Pressure: 50kPa

Date: 29<sup>th</sup>, Jun 2021





## **Trelleborg Marine Engineering (Qingdao) Co., Ltd**

No.35, Ronghai 4 Road, Chengyang District, Qingdao 266111, China

The following pneumatic rubber fender components were examined, tested in accordance with the purchase order and specifications requirements.

1. Towing lug
2. Shackles
3. Swivel shackles
4. Chain



青岛天顺达机械制造有限公司

QINGDAO TAI STAR MACHINERY CO., LTD

证书编号: TSD200701-1  
CERTIFICATE NO.: TSD200701-1

工厂检测证书

MILL CERTIFICATE AND CERTIFICATE OF QUANTITY

采购方: 特瑞堡海洋工程(青岛)有限公司

PURCHASER: Trelleborg Marine Engineering (Qingdao) Co., Ltd

货物描述

DESCRIPTION OF PRODUCT

1、货物: 1350-2000 拖拽吊耳

PRODUCT: P1320TOWINGL

规格尺寸: 详见以下图纸

SPECIFICATION: ACCORDING TO APPROVAL DRAWING

材质: Q345B

MATERIAL: Q345B

数量: 8件

QUANTITY: 8PCS

表面处理: 热镀锌

SURFACE FINISHED: HOP DIP GALVANIZED

是否合格: 是

APPEARANCE: CHECK OUT

所有尺寸均按照图纸进行生产 ALL SIZES MADE ACCORDING TO THE DRAWING

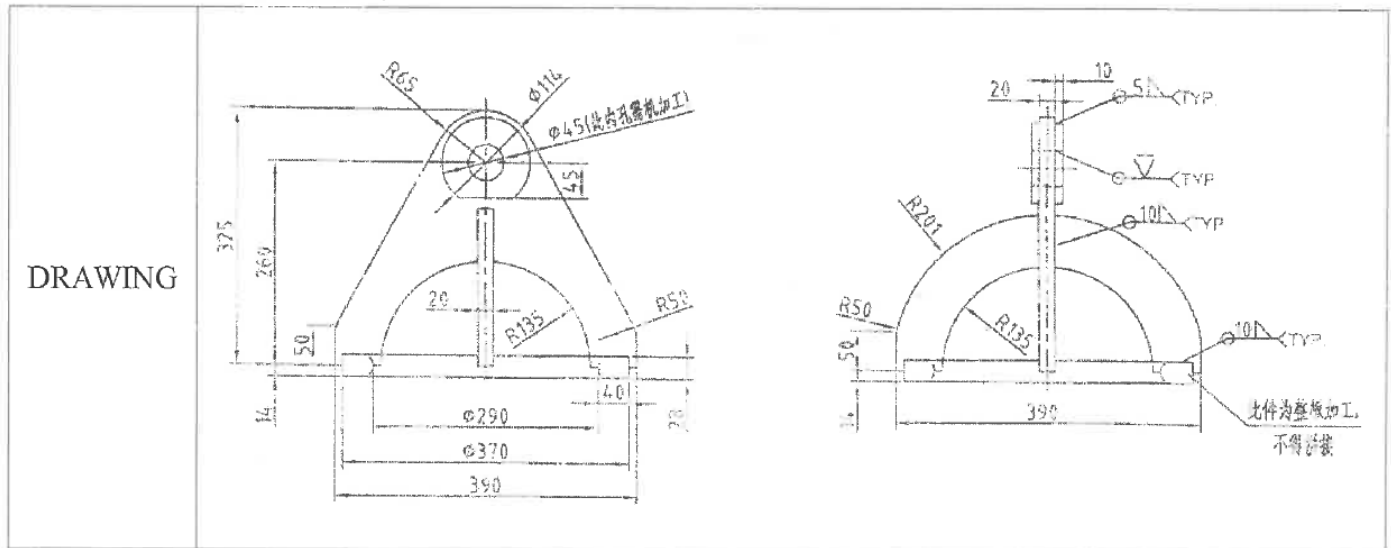

2、货物: G2130 卸扣 1"

PRODUCT: G2130 SHACKLE 1"

卸扣名义尺寸 NOMINAL SIZE OF SHACKLE

直径: 25 MM

额定载荷: 8.5 T

数量: 16 件

DIAMETER: 25 MM

WLL: 8.5 T

QUANTITY: 16 PCS

拉力负荷: 170 KN

PROOF TEST LOAD: 170 KN

破断负荷: 510 KN

BREAKING LOAD: 510 KN

3、货物: G210 卸扣 3/4"

PRODUCT: G210 SHACKLE 3/4"

卸扣名义尺寸 NOMINAL SIZE OF SHACKLE

直径: 19 MM                      额定载荷: 4.75 T                      数量: 52 件  
DIAMETER: 19 MM                      WLL: 4.75 T                      QUANTITY: 52 PCS  
拉力负荷: 95 KN                      PROOF TEST LOAD: 95 KN  
破断负荷: 285 KN                      BREAKING LOAD: 285 KN

4、货物: G402 旋转环 1”

PRODUCT: G402 SWIVEL 1”

卸扣名义尺寸 NOMINAL SIZE OF SHACKLE

直径: 25 MM                      额定载荷: 5.5 T                      数量: 8 件  
DIAMETER: 25 MM                      WLL: 5.5 T                      QUANTITY: 8 PCS  
表面处理: 热镀锌 ≥85 UM                      SURFACE FINISHED: H.D.G. ≥85 UM

5、货物: 蝴蝶卸扣 10MM

PRODUCT: HAMMER LOCK 10MM

卸扣名义尺寸 NOMINAL SIZE OF SHACKLE

额定载荷: 3.15 T                      数量: 200 件  
WLL: 3.15 T                      QUANTITY: 200 PCS  
拉力负荷: 63 KN                      PROOF TEST LOAD: 63 KN  
破断负荷: 126 KN                      BREAKING LOAD: 126 KN  
表面处理: 热镀锌 ≥85 UM                      SURFACE FINISHED: H.D.G. ≥85 UM

6、货物: 12MM 二级无档链\*224M/条

PRODUCT: U2 12MM OPEN LINK CHAIN\*224M/LENGTH

链环名义尺寸 NOMINAL SIZE OF CHAIN LINKS

直径: 12 MM                      内长: 66 MM                      内宽: 24 MM  
DIAMETER: 12 MM                      INSIDE LENGTH: 66 MM                      INSIDE WIDTH: 24 MM  
数量: 224 米×1 条                      QUANTITY: 224M×1PC  
拉力负荷: 39.5 KN                      CHAIN PROOF LOAD: 39.5 KN  
破断负荷: 79.2 KN                      CHAIN BREAKING LOAD: 79.2 KN  
表面处理: 热镀锌 ≥85 UM                      SURFACE FINISHED: H.D.G. ≥85 UM  
链条公差: +2.5%/-0                      SIZE TOLERANCE: +2.5%/-0

合同/订单编号 (CONTRACT NO.): 4500035155/ T2005188

兹证明上述产品经本厂检验和试验, 符合本厂规范和批准图纸要求, 可以使用。

THIS IS TO CERTIFY THAT THE ABOVE-MENTIONED GOODS HAVE BEEN INSPECTED AND TESTED BY OUR FACTORY AND FOUND TO BE IN COMPLIANCE WITH STANDARD OF OUR FACTORY AND THAT IT IS FIT FOR USE.

检验员: 宋修君                      批准: 蓝孝柱                      发证日期: 2020年07月01日

INSPECTOR: XIUJUN SONG                      APPROVER: XIAOZHU LAN                      DATE OF ISSUE: 2020-07-01



1.5x3.0



青岛天顺达机械制造有限公司

QINGDAO TAI STAR MACHINERY CO., LTD

证书编号: TSD210315-1

CERTIFICATE NO.: TSD210315-1

工厂检测证书

MILL CERTIFICATE AND CERTIFICATE OF QUANTITY

采购方: 特瑞堡海洋工程(青岛)有限公司

PURCHASER: Trelleborg Marine Engineering (Qingdao) Co., Ltd

货物描述

DESCRIPTION OF PRODUCT

1、货物: 12MM 二级无档链\*50M/条

PRODUCT: U2 12MM OPEN LINK CHAIN\*50M/LENGTH

链环名义尺寸 NOMINAL SIZE OF CHAIN LINKS

直径: 12 MM 内长: 66 MM 内宽: 24 MM

DIAMETER: 12 MM INSIDE LENGTH: 66 MM INSIDE WIDTH: 24 MM

数量: 50 米\*2 条 QUANTITY: 50M\*2PCS

拉力负荷: 39.5 KN CHAIN PROOF LOAD: 39.5 KN

破断负荷: 79.2 KN CHAIN BREAKING LOAD: 79.2 KN

表面处理: 热镀锌 ≥85 UM SURFACE FINISHED: H.D.G. ≥85 UM

链条公差: +2.5%/-0 SIZE TOLERANCE: +2.5%/-0

2、货物: 1350-2000 拖拽吊耳

PRODUCT: P1320TOWINGL

规格尺寸: 详见以下图纸

SPECIFICATION: ACCORDING TO APPROVAL DRAWING

材 质: Q345B MATERIAL: Q345B

数 量: 4 件 QUANTITY: 4PCS

表 面 处 理: 热镀锌 SURFACE FINISHED: HOP DIP GALVANIZED

是 否 合 格: 是 APPEARANCE: CHECK OUT

所有尺寸均按照图纸进行生产 ALL SIZES MADE ACCORDING TO THE DRAWING

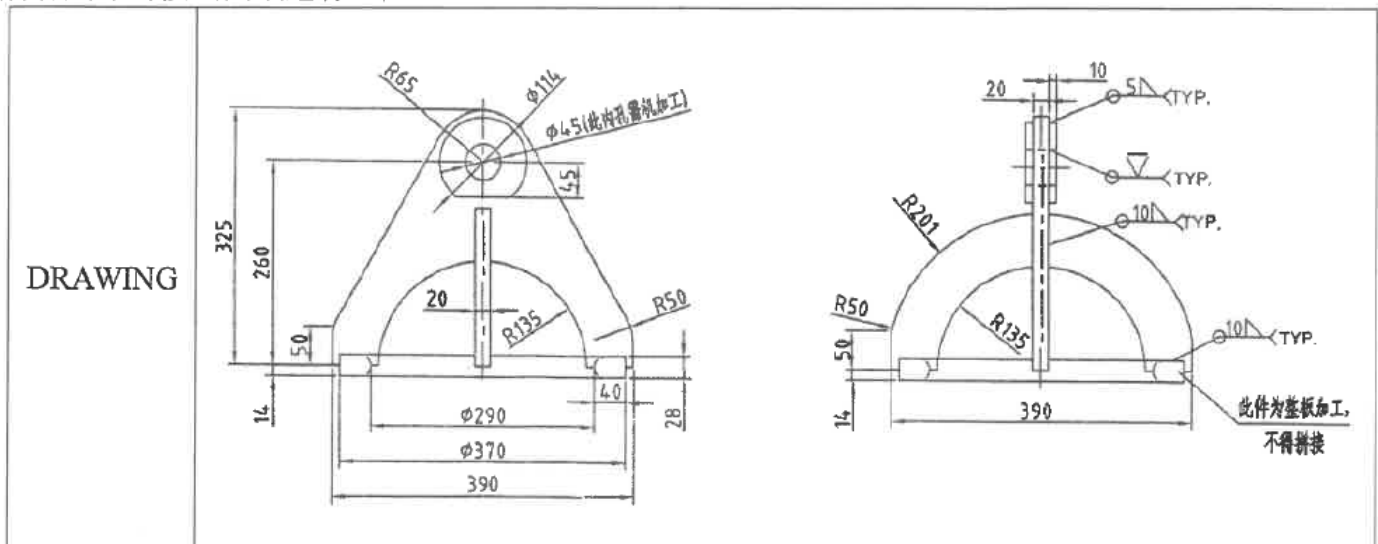

3、货物：G210 卸扣 3/4"  
PRODUCT: G210 SHACKLE 3/4"  
卸扣名义尺寸 NOMINAL SIZE OF SHACKLE  
直径: 19 MM 额定载荷: 4.75 T 数量: 28 件  
DIAMETER: 19 MM WLL: 4.75 T QUANTITY: 28 PCS  
拉力负荷: 95 KN PROOF TEST LOAD: 95 KN  
破断负荷: 285 KN BREAKING LOAD: 285 KN  
表面处理: 热镀锌≥85 UM SURFACE FINISHED: H.D.G.≥85 UM

4、货物：G2130 卸扣 1"  
PRODUCT: G2130 SHACKLE 1"  
卸扣名义尺寸 NOMINAL SIZE OF SHACKLE  
直径: 25 MM 额定载荷: 8.5 T 数量: 8 件  
DIAMETER: 25 MM WLL: 8.5 T QUANTITY: 8 PCS  
拉力负荷: 170 KN PROOF TEST LOAD: 170 KN  
破断负荷: 510 KN BREAKING LOAD: 510 KN  
表面处理: 热镀锌≥85 UM SURFACE FINISHED: H.D.G.≥85 UM

5、货物：G402 旋转环 1"  
PRODUCT: G402 SWIVEL 1"  
卸扣名义尺寸 NOMINAL SIZE OF SHACKLE  
直径: 25 MM 额定载荷: 5.5 T 数量: 4 件  
DIAMETER: 25 MM WLL: 5.5 T QUANTITY: 4 PCS  
表面处理: 热镀锌≥85 UM SURFACE FINISHED: H.D.G.≥85 UM

合同/定单编号 (CONTRACT NO.) : 4500037458 / T2101032

兹证明上述产品经本厂检验和试验,符合本厂规范和批准图纸要求,可以使用。

THIS IS TO CERTIFY THAT THE ABOVE-MENTIONED GOODS HAVE BEEN INSPECTED AND TESTED BY OUR FACTORY AND FOUND TO BE IN COMPLIANCE WITH STANDARD OF OUR FACTORY AND THAT IT IS FIT FOR USE.

检验员: 宋修君 批准: 蓝孝柱 发证日期: 2021年3月15日  
INSPECTOR: XIUJUN SONG APPROVER: XIAOZHU LAN DATE OF ISSUE: 2021-03-15

