



# PNEUMATIC FENDER ACCESSORIES

## Inspection Report

Product Name: Pneumatic fender  $\Phi$ 2000x3500L

Purchase order: PNE-STOCK ORDER 001-P.O. NO.90670

Initial Internal Pressure: 50kPa

Date: 29<sup>th</sup>, Jun 2021





## **Trelleborg Marine Engineering (Qingdao) Co., Ltd**

No.35, Ronghai 4 Road, Chengyang District, Qingdao 266111, China

The following pneumatic rubber fender components were examined, tested in accordance with the purchase order and specifications requirements.

1. Shackles
2. Swivel shackles
3. Chain
4. Towing lug



青 岛 天 顺 达 机 械 制 造 有 限 公 司

QINGDAO TAI STAR MACHINERY CO., LTD

证书编号: TSD210128-1

CERTIFICATE NO.: TSD210128-1

工厂检测证书

MILL CERTIFICATE AND CERTIFICATE OF QUANTITY

采购方: 特瑞堡海洋工程(青岛)有限公司

PURCHASER: Trelleborg Marine Engineering (Qingdao) Co., Ltd

货物描述

DESCRIPTION OF PRODUCT

1、货物: 12MM 二级无档链\*50M/条

PRODUCT: U2 12MM OPEN LINK CHAIN\*50M/LENGTH

链环名义尺寸 NOMINAL SIZE OF CHAIN LINKS

直径: 12 MM

内长: 66 MM

内宽: 24 MM

DIAMETER: 12 MM

INSIDE LENGTH: 66 MM

INSIDE WIDTH: 24 MM

数量: 50 米×2 条

QUANTITY: 50M×2PCS

拉力负荷: 39.5 KN

CHAIN PROOF LOAD: 39.5 KN

破断负荷: 79.2 KN

CHAIN BREAKING LOAD: 79.2 KN

表面处理: 热镀锌≥85 UM

SURFACE FINISHED: H.D.G. ≥85 UM

链条公差: +2.5%/-0

SIZE TOLERANCE: +2.5%/-0

合同/定单编号 (CONTRACT NO.): 4500037236 / T2101005

兹证明上述产品经本厂检验和试验,符合本厂规范和批准图纸要求,可以使用。

THIS IS TO CERTIFY THAT THE ABOVE-MENTIONED GOODS HAVE BEEN INSPECTED AND TESTED BY OUR FACTORY AND FOUND TO BE IN COMPLIANCE WITH STANDARD OF OUR FACTORY AND THAT IT IS FIT FOR USE.

检验员: 宋修君

批准: 蓝孝柱

发证日期: 2021年1月28日

INSPECTOR: XIUJUN SONG APPROVER: XIAOZHU LAN DATE OF ISSUE: 2021-01-28





青岛天顺达机械制造有限公司

QINGDAO TAI STAR MACHINERY CO., LTD

证书编号: TSD210618-2

CERTIFICATE NO.: TSD210618-2

工厂检测证书

MILL CERTIFICATE AND CERTIFICATE OF QUANTITY

采购方: 特瑞堡海洋工程(青岛)有限公司

PURCHASER: Trelleborg Marine Engineering (Qingdao) Co., Ltd

货物描述

DESCRIPTION OF PRODUCT

1、货物: 16MM 二级无档链\*50M/条

PRODUCT: U2 16MM OPEN LINK CHAIN\*50M/LENGTH

链环名义尺寸 NOMINAL SIZE OF CHAIN LINKS

直径: 16 MM 外长: 96 MM 外宽: 57.6 MM

DIAMETER: 16 MM OUTSIDE LENGTH: 96 MM OUTSIDE WIDTH: 57.6 MM

数量: 50M\*12条 QUANTITY: 50M\*12PCS

拉力负荷: 66.2 KN CHAIN PROOF LOAD: 66.2 KN

破断负荷: 132.3 KN CHAIN BREAKING LOAD: 132.3 KN

表面处理: 热镀锌 ≥85 UM SURFACE FINISHED: H.D.G. ≥85 UM

链条公差: +2.5%/-0 SIZE TOLERANCE: +2.5%/-0

2、货物: 1350-2000 拖拽吊耳 1.5 + 2.0

PRODUCT: P1320TOWINGL

规格尺寸: 详见以下图纸

SPECIFICATION: ACCORDING TO APPROVAL DRAWING

材 质: Q345B MATERIAL: Q345B

数 量: 12件 QUANTITY: 12PCS

表 面 处 理: 热镀锌 SURFACE FINISHED: HOP DIP GALVANIZED

是 否 合 格: 是 APPEARANCE: CHECK OUT

所有尺寸均按照图纸进行生产 ALL SIZES MADE ACCORDING TO THE DRAWING

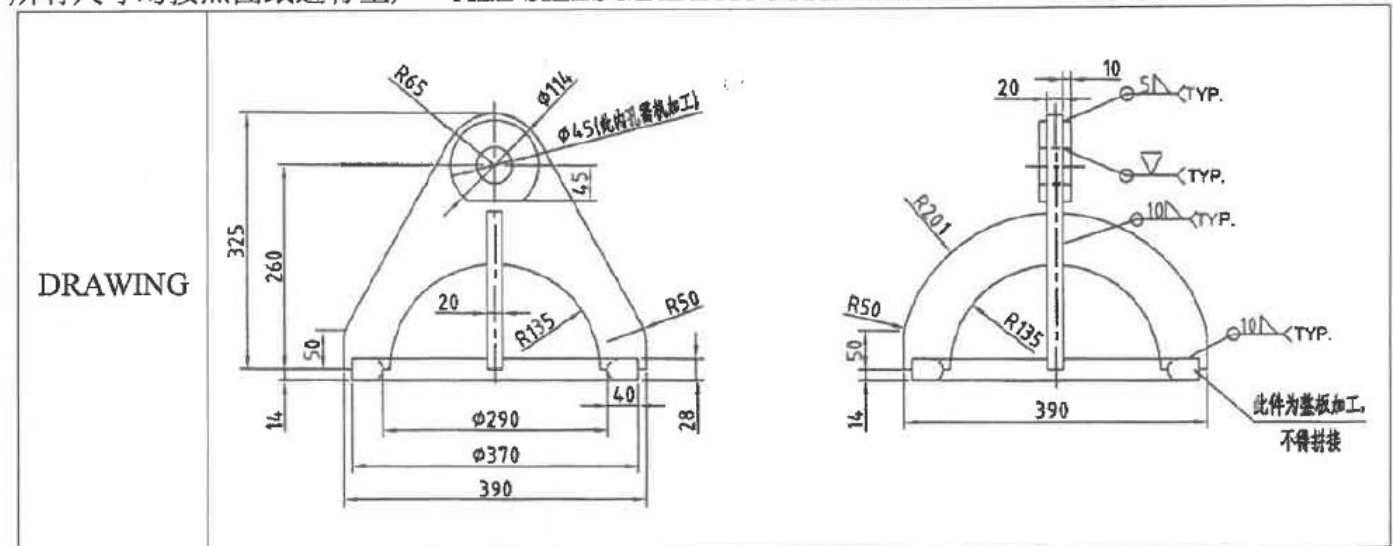

3、货物: G402 旋转环 1"

PRODUCT: G402 SWIVEL 1" 1.5

卸扣名义尺寸 NOMINAL SIZE OF SHACKLE

直径: 25 MM 额定载荷: 5.5 T 数量: 4 件  
DIAMETER: 25 MM WLL: 5.5 T QUANTITY: 4 PCS  
表面处理: 热镀锌≥85 UM SURFACE FINISHED: H.D.G.≥85 UM

4、货物: 蝴蝶卸扣 13MM 2.0  
PRODUCT: HAMMER LOCK 13MM

卸扣名义尺寸 NOMINAL SIZE OF SHACKLE

额定载荷: 5.3 T 数量: 200 件  
WLL: 5.3 T QUANTITY: 200 PCS  
拉力负荷: 106 KN PROOF TEST LOAD: 106 KN  
破断负荷: 212 KN BREAKING LOAD: 212 KN  
表面处理: 热镀锌≥85 UM SURFACE FINISHED: H.D.G.≥85 UM

5、货物: G210 卸扣 3/4" 1.5+2.0  
PRODUCT: G210 SHACKLE 3/4"

卸扣名义尺寸 NOMINAL SIZE OF SHACKLE

直径: 19 MM 额定载荷: 4.75 T 数量: 140 件  
DIAMETER: 19 MM WLL: 4.75 T QUANTITY: 140 PCS  
拉力负荷: 95 KN PROOF TEST LOAD: 95 KN  
破断负荷: 285 KN BREAKING LOAD: 285 KN  
表面处理: 热镀锌≥85 UM SURFACE FINISHED: H.D.G.≥85 UM

6、货物: G2130 卸扣 1-1/4" 2.0  
PRODUCT: G2130 SHACKLE 1-1/4"

卸扣名义尺寸 NOMINAL SIZE OF SHACKLE

直径: 32 MM 额定载荷: 12 T 数量: 16 件  
DIAMETER: 32 MM WLL: 12 T QUANTITY: 16 PCS  
拉力负荷: 240 KN PROOF TEST LOAD: 240 KN  
破断负荷: 720 KN BREAKING LOAD: 720 KN  
表面处理: 热镀锌≥85 UM SURFACE FINISHED: H.D.G.≥85 UM

7、货物: G402 旋转环 1-1/4" 2.0  
PRODUCT: G402 SWIVEL 1-1/4"

卸扣名义尺寸 NOMINAL SIZE OF SHACKLE

直径: 32 MM 额定载荷: 8 T 数量: 8 件  
DIAMETER: 32 MM WLL: 8 T QUANTITY: 8 PCS  
表面处理: 热镀锌≥85 UM SURFACE FINISHED: H.D.G.≥85 UM

合同/定单编号 (CONTRACT NO.): 4500038552 / T2105196

兹证明上述产品经本厂检验和试验,符合本厂规范和批准图纸要求,可以使用。

THIS IS TO CERTIFY THAT THE ABOVE-MENTIONED GOODS HAVE BEEN INSPECTED AND TESTED BY OUR FACTORY AND FOUND TO BE IN COMPLIANCE WITH STANDARD OF OUR FACTORY AND THAT IT IS FIT FOR USE.

检验员: 宋修君 批准: 蓝孝柱 发证日期: 2021年6月18日

INSPECTOR: XIUJUN SONG APPROVER: XIAOZHU LAN DATE OF ISSUE: 2021-06-18

